

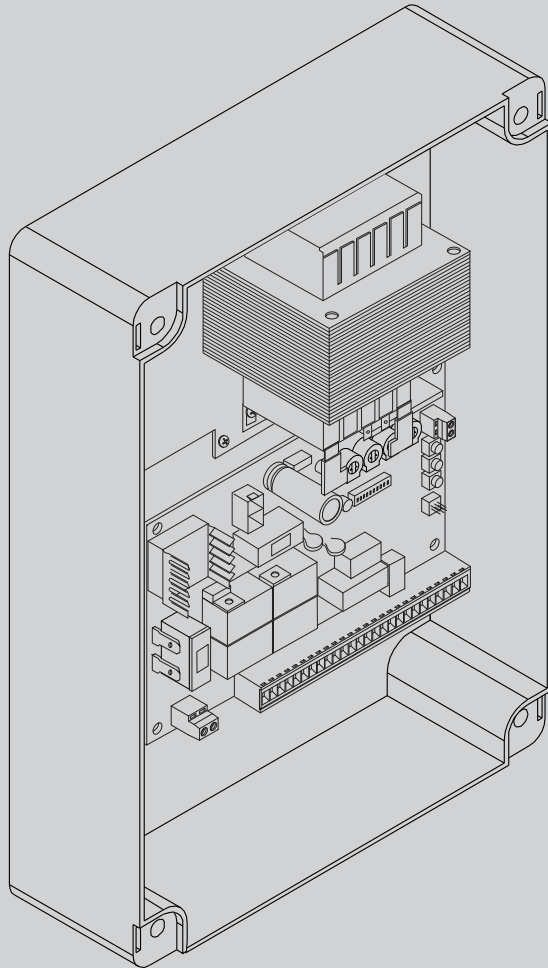

QUADRO COMANDO
CONTROL PANEL
CENTRALE DE COMMANDE
SELBSTÜBERWACHENDE STEUERUNG
CUADRO DE MANDOS
BEDIENINGSPANEEL



ISTRUZIONI DI INSTALLAZIONE
INSTALLATION MANUAL
INSTRUCTIONS D'INSTALLATION
MONTAGEANLEITUNG
INSTRUCCIONES DE INSTALACION
INSTALLATIEVOORSCHRIFTEN

ZARA BTL2



AZIENDA CON SISTEMA DI GESTIONE
INTEGRATO CERTIFICATO DA DNV
= UNI EN ISO 9001:2008 =
UNI EN ISO 14001:2004

INSTALLAZIONE VELOCE-QUICK INSTALLATION INSTALLATION RAPIDE - INSTALACIÓN RÁPIDA

D812059 00100_02

PREDISPOSIZIONE TUBI, TUBE ARRANGEMENT, PRÉDISPOSITION DES TUYAUX, VORBEREITUNG DER LEITUNGEN, DISPOSICIÓN DE TUBOS, VOORBEREIDING LEIDINGEN.

A

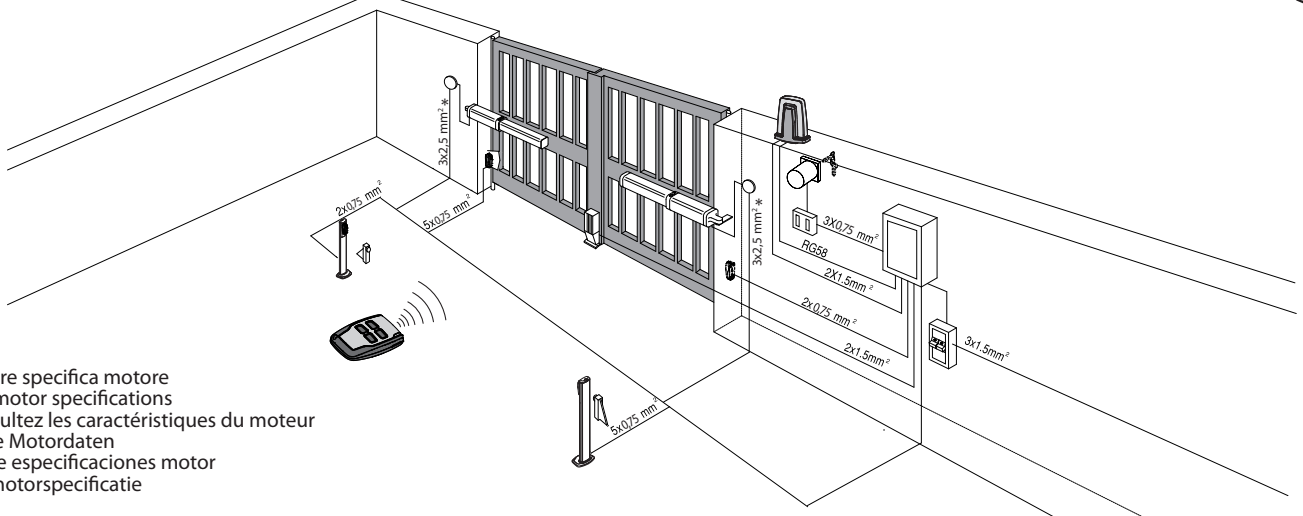

* Vedere specifica motore
See motor specifications
Consultez les caractéristiques du moteur
Siehe Motordaten
Véase especificaciones motor
Zie motorspecificatie

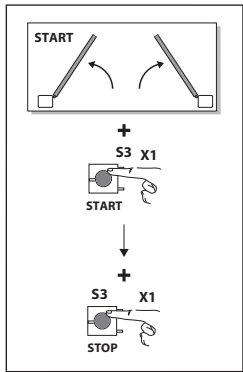

Antenna
Antenne
Antenna
Antenne

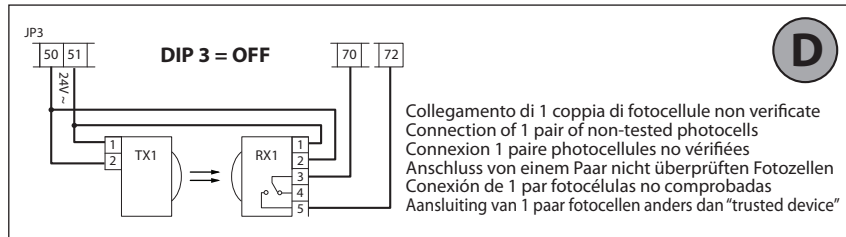
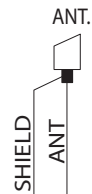

Collegamento di 1 coppia di fotocellule non verificate
Connection of 1 pair of non-tested photocells
Connexion 1 paire photocellules non vérifiées
Anschluss von einem Paar nicht überprüften Fotozellen
Conexión de 1 par fotocélulas no comprobadas
Aansluiting van 1 paar fotocellen anders dan "trusted device"

D

C

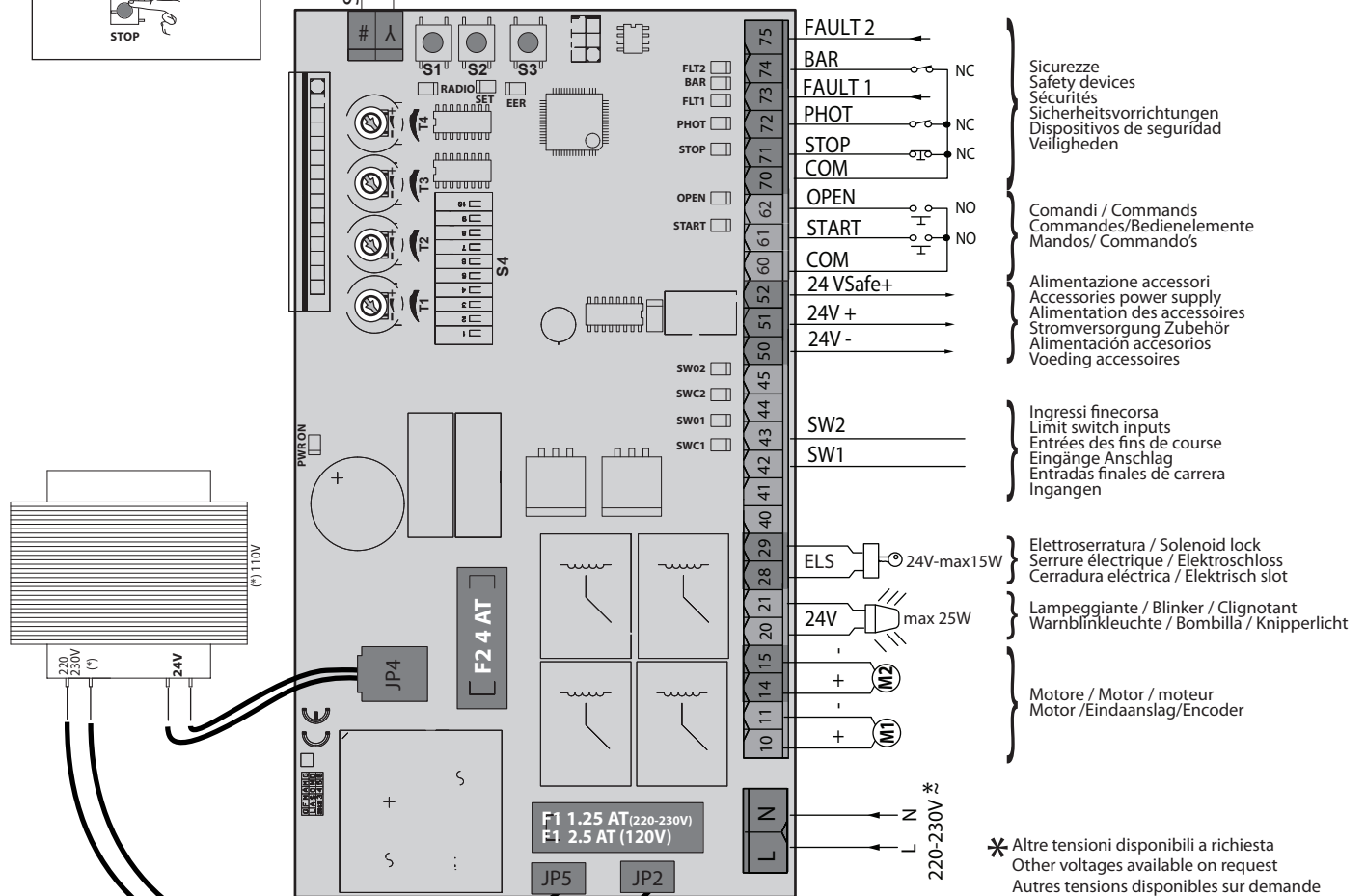

Sicurezza
Safety devices
Sécurité
Sicherheitsvorrichtungen
Dispositivos de seguridad
Veiligheden

Comandi / Commands
Commandes/Bedienelemente
Mandos/Commandos

Alimentazione accessori
Accessories power supply
Alimentation des accessoires
Stromversorgung Zubehör
Alimentación accesorios
Voeding accessoires

Ingressi finecorsa
Limit switch inputs
Entrées des fins de course
Eingänge Anschlag
Entradas finales de carrera
Ingangen

Elettroserratura / Solenoid lock
Serrure électrique / Elektroschloss
Cerradura eléctrica / Elektrisch slot

Lampeggiante / Blinker / Clignotant
Warnblinkleuchte / Bombilla / Knipperlicht

Motore / Motor / moteur
Motor/Eindaanslag/Encoder

* Altre tensioni disponibili a richiesta
Other voltages available on request
Autres tensions disponibles sur demande
Weitere Spannungen auf Anfrage erhältlich
Otras tensiones disponibles a petición
Andere spanningen op aanvraag beschikbaar

**MEMORIZZAZIONE RADIOCOMANDO/MEMORIZING REMOTE CONTROLS/MÉMORISATION RADIOCOMMANDE
ABSPEICHERUNG DER FERNBEDIENUNG / MEMORIZACIÓN DEL RADIOMANDO/MEMORIZAÇÃO DO RADIOCOMANDO**

E

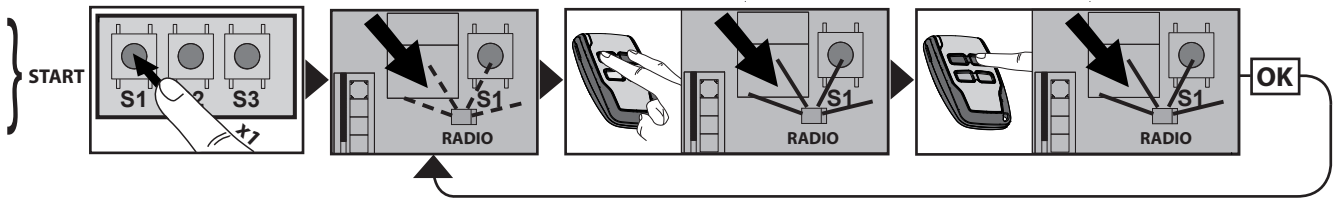

LEGENDA - KEY - LÉGENDE - LEGENDE - LEYENDA - LEGENDA

Fisso Steadily lit Fixe Ununterbrochen an Fijo Continu		Lampeggio continuo Continuous flashing Clignotement continu Kontinuierliches Blinken Parpadeo continuo Continu knipperen		Lampeggio intermittente Intermittent flashing Clignotement intermittent intermittierendes Blinken Parpadeo intermitente Met intervallen knipperen	
---	--	---	--	--	--

**REGOLAZIONE AUTOSET, ADJUSTING AUTOSET
RÉGLAGE AUTOSET, EINSTELLUNG AUTOSET
REGULACIÓN AUTOSET, REGULAÇÃO AUTOSET.**

F

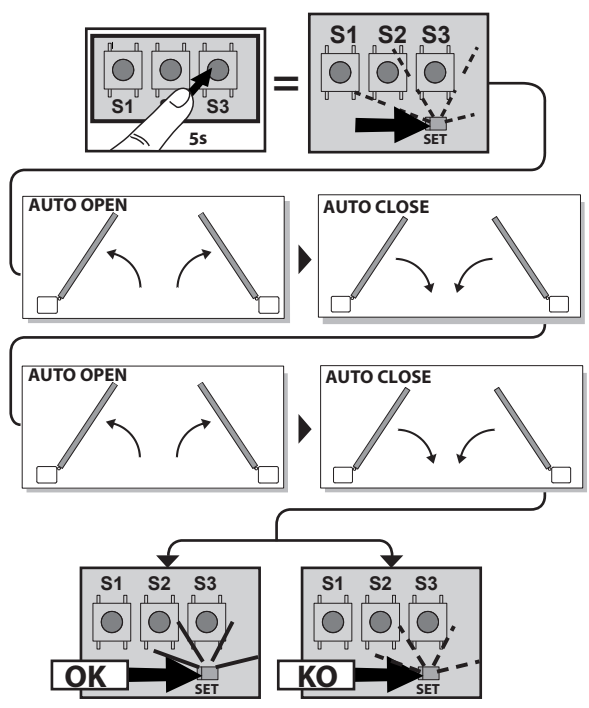

G

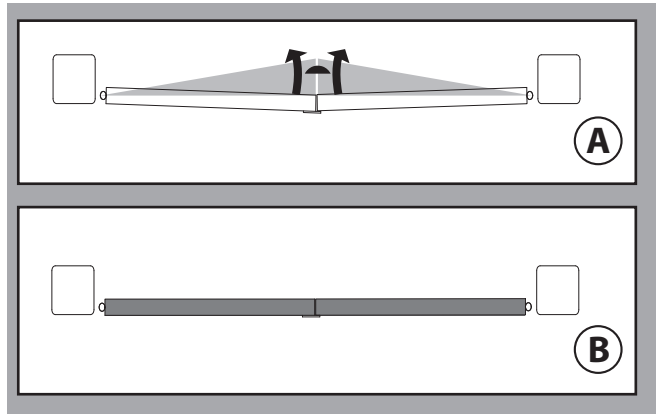

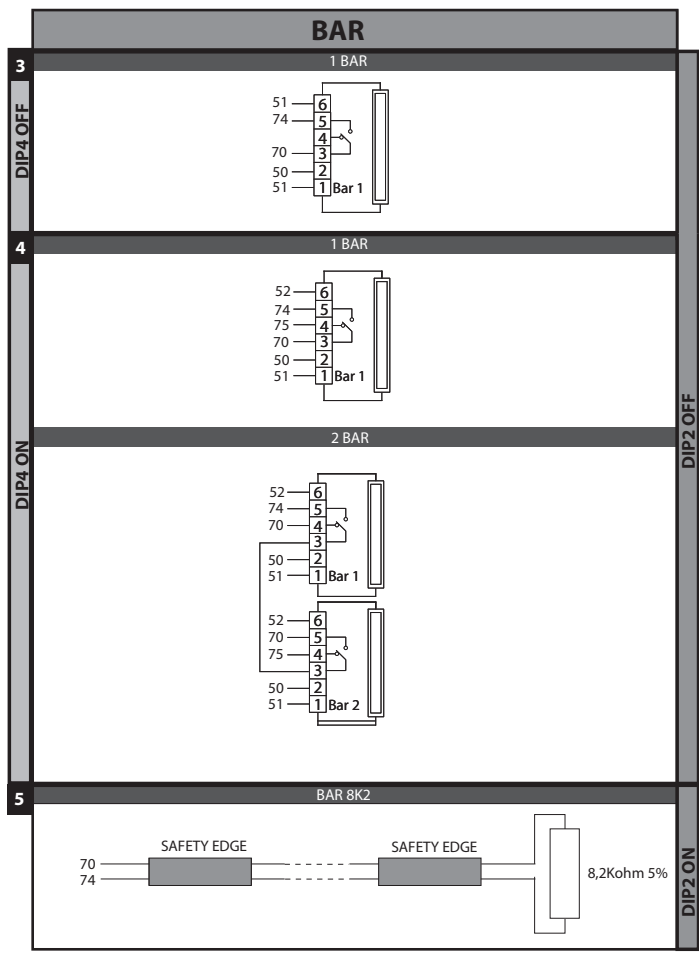
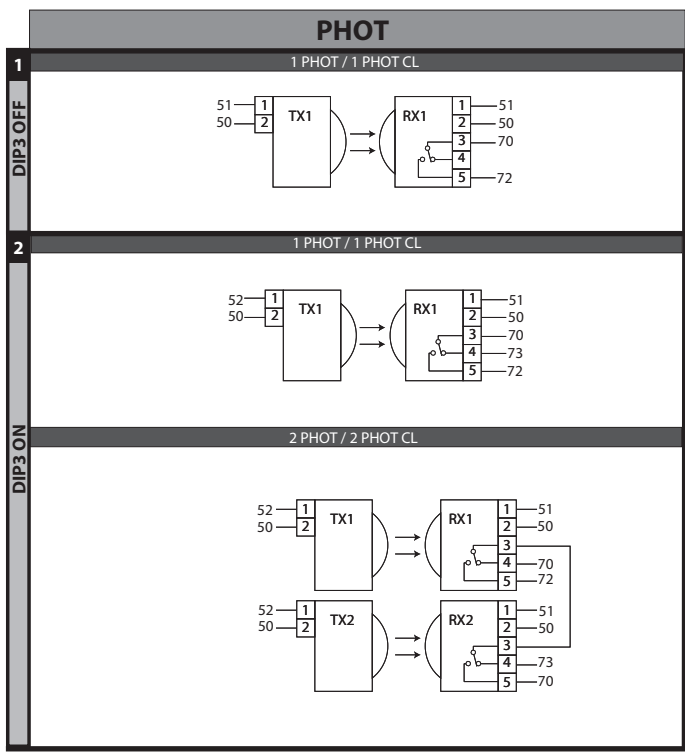
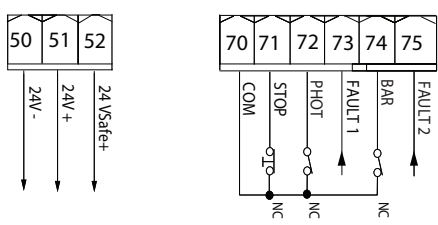

INSTALLER WARNINGS

WARNING! Important safety instructions. Carefully read and comply with all the warnings and instructions that come with the product as incorrect installation can cause injury to people and animals and damage to property. The warnings and instructions give important information regarding safety, installation, use and maintenance. Keep hold of instructions so that you can attach them to the technical file and keep them handy for future reference.

GENERAL SAFETY

This product has been designed and built solely for the purpose indicated herein. Uses other than those indicated herein might cause damage to the product and create a hazard.

- The units making up the machine and its installation must meet the requirements of the following European Directives, where applicable: 2004/108/EC, 2006/95/EC, 2006/42/EC, 89/106/EC, 99/05/EC and later amendments. For all countries outside the EEC, it is advisable to comply with the standards mentioned, in addition to any national standards in force, to achieve a good level of safety.
- The Manufacturer of this product (hereinafter referred to as the "Firm") disclaims all responsibility resulting from improper use or any use other than that for which the product has been designed, as indicated herein, as well as for failure to apply Good Practice in the construction of entry systems (doors, gates, etc.) and for deformation that could occur during use.
- Installation must be carried out by qualified personnel (professional installer, according to EN 12635), in compliance with Good Practice and current code.
- Before installing the product, make all structural changes required to produce safety gaps and to provide protection from or isolate all crushing, shearing and dragging hazard areas and danger zones in general in accordance with the provisions of standards EN 12604 and 12453 or any local installation standards. Check that the existing structure meets the necessary strength and stability requirements.
- Before commencing installation, check the product for damage.
- The Firm is not responsible for failure to apply Good Practice in the construction and maintenance of the doors, gates, etc. to be motorized, or for deformation that might occur during use.
- Make sure the stated temperature range is compatible with the site in which the automated system is due to be installed.
- Do not install this product in an explosive atmosphere: the presence of flammable fumes or gas constitutes a serious safety hazard.
- Disconnect the electricity supply before performing any work on the system. Also disconnect buffer batteries, if any are connected.
- Before connecting the power supply, make sure the product's ratings match the mains ratings and that a suitable residual current circuit breaker and overcurrent protection device have been installed upline from the electrical system. Have the automated system's mains power supply fitted with a switch or omnipolar thermal-magnetic circuit breaker with a contact separation that provide full disconnection under overvoltage category III conditions.
- Make sure that upline from the mains power supply there is a residual current circuit breaker that trips at no more than 0.03A as well as any other equipment required by code.
- Make sure the earth system has been installed correctly: earth all the metal parts belonging to the entry system (doors, gates, etc.) and all parts of the system featuring an earth terminal.
- Installation must be carried out using safety devices and controls that meet standards EN 12978 and EN 12453.
- Impact forces can be reduced by using deformable edges.
- In the event impact forces exceed the values laid down by the relevant standards, apply electro-sensitive or pressure-sensitive devices.
- Apply all safety devices (photocells, safety edges, etc.) required to keep the area free of impact, crushing, dragging and shearing hazards. Bear in mind the standards and directives in force, Good Practice criteria, intended use, the installation environment, the operating logic of the system and forces generated by the automated system.
- Apply all signs required by current code to identify hazardous areas (residual risks). All installations must be visibly identified in compliance with the provisions of standard EN 13241-1.
- Once installation is complete, apply a nameplate featuring the door/gate's data.
- This product cannot be installed on leaves incorporating doors (unless the motor can be activated only when the door is closed).
- If the automated system is installed at a height of less than 2.5 m or is accessible, the electrical and mechanical parts must be suitably protected.
- Install any fixed controls in a position where they will not cause a hazard, away from moving parts. More specifically, hold-to-run controls must be positioned within direct sight of the part being controlled and, unless they are key operated, must be installed at a height of at least 1.5 m and in a place where they cannot be reached by the public.
- Apply at least one warning light (flashing light) in a visible position, and also attach a Warning sign to the structure.
- Attach a label near the operating device, in a permanent fashion, with information on how to operate the automated system's manual release.
- Make sure that, during operation, mechanical risks are avoided or relevant protective measures taken and, more specifically, that nothing can be banged, crushed, caught or cut between the part being operated and surrounding parts.
- Once installation is complete, make sure the motor automation settings are correct and that the safety and release systems are working properly.
- Only use original spare parts for any maintenance or repair work. The Firm disclaims all responsibility for the correct operation and safety of the automated system if parts from other manufacturers are used.
- Do not make any modifications to the automated system's components unless explicitly authorized by the Firm.
- Instruct the system's user on what residual risks may be encountered, on the control systems that have been applied and on how to open the system manually in an emergency. Give the user guide to the end user.
- Dispose of packaging materials (plastic, cardboard, polystyrene, etc.) in accordance with the provisions of the laws in force. Keep nylon bags and polystyrene out of reach of children.

WIRING

WARNING! For connection to the mains power supply, use: a multicore cable with a cross-sectional area of at least 5x1.5mm² or 4x1.5mm² when dealing with three-phase power supplies or 3x1.5mm² for single-phase supplies (by way of example, type H05 VV-F cable can be used with a cross-sectional area of 4x1.5mm²). To connect auxiliary equipment, use wires with a cross-sectional area of at least 0.5 mm².

- Only use pushbuttons with a capacity of 10A-250V or more.
- Wires must be secured with additional fastening near the terminals (for example, using cable clamps) in order to keep live parts well separated from safety extra low voltage parts.
- During installation, the power cable must be stripped to allow the earth wire to be connected to the relevant terminal, while leaving the live wires as short as possible. The earth wire must be the last to be pulled taut in the event the cable's fastening device comes loose.

WARNING! safety extra low voltage wires must be kept physically separate from low voltage wires.

Only qualified personnel (professional installer) should be allowed to access live parts.

CHECKING THE AUTOMATED SYSTEM AND MAINTENANCE

Before the automated system is finally put into operation, and during maintenance work, perform the following checks meticulously:

- Make sure all components are fastened securely.
- Check starting and stopping operations in the case of manual control.
- Check the logic for normal or personalized operation.
- For sliding gates only: check that the rack and pinion mesh correctly with 2 mm of play along the full length of the rack; keep the track the gate slides on clean and free of debris at all times.
- For sliding gates and doors only: make sure the gate's running track is straight and horizontal and that the wheels are strong enough to take the weight of the gate.
- For cantilever sliding gates only: make sure there is no dipping or swinging during operation.
- For swing gates only: make sure the leaves' axis of rotation is perfectly vertical.
- For barriers only: before opening the door, the spring must be decompressed (vertical boom).
- Check that all safety devices (photocells, safety edges, etc.) are working properly and that the anti-crush safety device is set correctly, making sure that the force of impact measured at the points provided for by standard EN 12445 is lower than the value laid down by standard EN 12453.
- Impact forces can be reduced by using deformable edges.
- Make sure that the emergency operation works, where this feature is provided.
- Check opening and closing operations with the control devices applied.
- Check that electrical connections and cabling are intact, making extra sure that insulating sheaths and cable glands are undamaged.
- While performing maintenance, clean the photocells' optics.
- When the automated system is out of service for any length of time, activate the emergency release (see "EMERGENCY OPERATION" section) so that the operated part is made idle, thus allowing the gate to be opened and closed manually.
- If the power cord is damaged, it must be replaced by the manufacturer or their technical assistance department or other such qualified person to avoid any risk.
- If "D" type devices are installed (as defined by EN 12453), connect in unverified mode, foresee mandatory maintenance at least every six months
- The maintenance described above must be repeated at least once yearly or at shorter intervals where site or installation conditions make this necessary.

WARNING!

Remember that the drive is designed to make the gate/door easier to use and will not solve problems as a result of defective or poorly performed installation or lack of maintenance



SCRAPPING

Materials must be disposed of in accordance with the regulations in force. Do not throw away your discarded equipment or used batteries with household waste. You are responsible for taking all your waste electrical and electronic equipment to a suitable recycling centre.

DISMANTLING

If the automated system is being dismantled in order to be reassembled at another site, you are required to:

- Cut off the power and disconnect the whole electrical system.
- Remove the actuator from the base it is mounted on.
- Remove all the installation's components.
- See to the replacement of any components that cannot be removed or happen to be damaged.

THE DECLARATION OF CONFORMITY CAN BE VIEWED ON THIS WEBSITE: WWW.BFT.IT IN THE PRODUCT SECTION.

Anything that is not explicitly provided for in the installation manual is not allowed. The operator's proper operation can only be guaranteed if the information given is complied with. The Firm shall not be answerable for damage caused by failure to comply with the instructions featured herein.

While we will not alter the product's essential features, the Firm reserves the right, at any time, to make those changes deemed opportune to improve the product from a technical, design or commercial point of view, and will not be required to update this publication accordingly.

INSTALLATION MANUAL

1) GENERAL INFORMATION

The **ZARA BTL2** control panel comes with standard factory settings. Any change must be set by means of the TRIMMER and DIP SWITCH settings.

The Control unit completely supports the EELINK protocol.

Its main features are:

- Control of 1 or 2 24V BT motors
Note: 2 motors of the same type must be used.
- Electronic torque control with obstacle detection
- Separate inputs for safety devices
- Built-in radio receiver rolling code with transmitter cloning.

The board has a terminal strip of the removable kind to make maintenance or replacement easier. It comes with a series of prewired jumpers to make the installer's job on site easier.

The jumpers concern terminals: 70-71, 70-72, 70-74. If the above-mentioned terminals are being used, remove the relevant jumpers.

TESTING

The **ZARA BTL2** panel controls (checks) the start relays and safety devices (photo-cells) before performing each opening and closing cycle.

If there is a malfunction, make sure that the connected devices are working properly and check the wiring.

2) TECHNICAL SPECIFICATIONS	
Power supply	220-230V 50/60 Hz*
Low voltage/mains insulation	> 2MΩ 500V ---
Operating temperature range	-20 / +55°C
Thermal overload protection	Software
Dielectric rigidity	mains/LV 3750V~ for 1 minute
Motor relay switching current	10A
Maximum motor power	40W + 40W (24V ---)
Accessories power supply	24V ~ (demand max. 0,2A) 24V ~ safe
Solenoid lock	24V ~ max. 15W

Flashing light	24V --- max. 25W
Fuses	see Fig. C
N° of combinations	4 billion
Max.n° of transmitters that can be memorized	63
Maximum work time	3 minutes
Maximum power	130W
Maximum cycle	S3 13s -1-13s-1x30 pause 90 min.

(*other voltages to order)

Usable transmitter versions:

All ROLLING CODE transmitters compatible with ((ER-Ready))

3) TUBE ARRANGEMENT Fig. A

Install the electrical system referring to the standards in force for electrical systems CEI 64-8, IEC 364, harmonization document HD 384 and other national standards.

4) TERMINAL BOARD WIRING Fig. C

WARNINGS - When performing wiring and installation, refer to the standards in force and, whatever the case, apply good practice principles.

Wires carrying different voltages must be kept physically separate from each other, or they must be suitably insulated with at least 1mm of additional insulation.

Wires must be secured with additional fastening near the terminals, using devices such as cable clamps.

All connecting cables must be kept far enough away from the dissipater.

WARNING! For connection to the mains power supply, use a multicore cable with a cross-sectional area of at least 3x1.5mm² of the kind provided for by the regulations in force.

To connect the motors, use a cable with a cross-sectional area of at least 1.5mm² of the kind provided for by the regulations in force. By way of example, if the cable is run outside (unprotected), it must be at least type H07RN-F, while if it is run inside (in a raceway), it must be at least type H05 VV-F.

	Terminal	Definition	Description
Power supply	L	LINE	Single-phase power supply 220-230V ~50/60 Hz*
	N	NEUTRAL	
	JP2	TRANSF PRIM	Transformer primary winding connection, 220-230V ~*
	JP5		
	JP4	TRANSF SEC	Board power supply: 24V~ Transformer secondary winding 24V= Buffer battery power supply
Motor	10	MOT 1 +	Connection motor 1. Time lag during closing. (T4)
	11	MOT 1 -	
	14	MOT 2 +	Connection motor 2. Time lag during opening. 2s
	15	MOT 2 -	
Aux	20	BLINKER 24V --- (MAX. 1A)	Flashing light 24V output max. 25W. Contact stays closed while leaf is operating.
	21		
	28	Solenoid lock	24V ~ max. 15W
	29		
Limit switches	40	Not used	
	41	Not used	
	42	SW1	Limit switch motor 1
	43	SW2	Limit switch motor 2
	44	Not used	
	45	Not used	
Accessories power supply	50	24V-	Accessories power supply output.
	51	24V+	
	52	24 Vsafe+	
Commands	60	Common	START and OPEN inputs common
	61	START	START command button (N.O.). Operation according to "3/4-STEP" logic
	62	OPEN	OPEN command button (N.O.). Gate opened with this command. If the input stays closed, the leaves stay open until the contact is opened. When the contact is open, the automated device closes following the TCA time, where activated.
Safety devices	70	Common	STOP, PHOT and BAR inputs common
	71	STOP	The command stops movement. (N.C.) If not used, leave jumper inserted.
	72	PHOT (**)	PHOTOCELL input (N.C.). Operation according to "PHOTOCELL/PHOTOCELL DURING CLOSING" logic. If not used, leave jumper inserted.
	73	FAULT 1	Test input for safety devices connected to PHOT.
	74	BAR (**)	BAR safety edge input (N.C.). Configurable according to the "BAR/ 8K2" logic. The command reverses movement for 2 sec. If not used, leave jumper inserted.
	75	FAULT 2	Test input for safety devices connected to BAR.
Antenna	Y	ANTENNA	Antenna input. Use an antenna tuned to 433MHz. Use RG58 coax cable to connect the Antenna and Receiver. Metal bodies close to the antenna can interfere with radio reception. If the transmitter's range is limited, move the antenna to a more suitable position.
	#	SHIELD	

(* Other voltages available on request

(* If "D" type devices are installed (as defined by EN12453), connect in unverified mode, foresee mandatory maintenance at least every six months.

5) LOCAL COMMANDS Fig. C

Pressing the S3 key commands one START. By pressing the key again while the automated device is moving a STOP is commanded.

6) SAFETY DEVICES

Note: only use receiving safety devices with free changeover contact.

6.1) TESTED DEVICES Fig. H**6.2) CONNECTION OF 1 PAIR OF NON-TESTED PHOTOCELLS Fig. D****7) MEMORIZING TRANSMITTERS FIG. E****RADIO**

IMPORTANT NOTE: THE FIRST TRANSMITTER MEMORIZED MUST BE IDENTIFIED BY ATTACHING THE KEY LABEL (MASTER).

In the event of manual programming, the first transmitter assigns the RECEIVER'S KEY CODE: this code is required to subsequently clone the radio transmitters. The Clonix built-in on-board receiver also has a number of important advanced features:

- Cloning of master transmitter (rolling code or fixed code).
- Cloning to replace transmitters already entered in receiver.

To use these advanced features, refer to the universal handheld programmer's instructions and to the general receiver programming guide.

8) AUTOSET ADJUSTMENT FIG. F

Enables Motor Torque to be set automatically.

If the power is suddenly disconnected and then restored the automation performs the operations at autosee speed till the travel limits are identified.

WARNING!! The autosee operation must be performed only once you have checked that the leaf is moving accurately (opening/closing) and that the mechanical stops are positioned correctly. You must run an autosee cycle whenever the motor force (T2), the slow-down distance (T3).

WARNING!! While the autosee function is running, the obstacle detection function is not active. Consequently, the installer must monitor the automated device's movements and keep people and property out of range of the automated device.

WARNING: the torque values set by the autosee function refer to the motor force set during the autosee cycle. If motor force is edited, an autosee opening and closing cycle will need to be performed again.

WARNING: check that the force of impact measured at the points provided for by standard EN 12445 is lower than the value laid down by standard EN 12453. Setting sensitivity incorrectly can result in damage to property and injury to people and animals.

SOLENOID LOCK

WARNING: In the case of leaves longer than 3m, it is essential to install a solenoid lock.

KEYS

KEYS	Description
S1	Add Start Key associates the desired key with the Start command.
S2	Add Pedestrian Key associates the desired key with the pedestrian command.
S2 >5s	Confirms the changes made to parameter settings and operating
S1+S2 >10s	Erase List  WARNING! Erases all memorized transmitters from the receiver's memory.
S3	Pressed BRIEFLY, it gives the START command. HELD DOWN (>5 sec.), it activates the AUTOSET function.

LED INDICATORS:

POWER	Steadily lit: - Mains power on - Board powered - Fuse F1 intact
START	Lit: START input activated
OPEN	Lit: OPEN pedestrian input activated
STOP	Unlit: STOP input activated
PHOT	Unlit: PHOT photocell input activated
FAULT 1	PHOT input safety device test input diagnostics
BAR	Unlit: BAR safety edge input activated
FAULT 2	BAR input safety device test input diagnostics
SWC1	Lit: the limit switch closing of motor 1 is free Unlit: motor 1 closing limit switch input activated
SWO1	Lit: the limit switch opening of motor 1 is free Unlit: motor 1 opening limit switch input activated
SWC2	Lit: the limit switch closing of motor 2 is free Unlit: motor 2 closing limit switch input activated
SWO2	Lit: the limit switch opening of motor 2 is free Unlit: motor 2 opening limit switch input activated
ERR	Unlit: no error LIT: see error diagnostics table

RADIO (GREEN)	Unlit: remote programming not active
	Radio LED only flashing: Remote programming active, waiting for hidden key.
	Flashing in sync with Set LED: Transmitter deletion in progress
	Lit: remote programming active, waiting for desired key.
	Lit 1s: Radio receiver channel activated
SET	Lit: Set key pressed / Autosee completed successfully
	Flashes three times: Autosee in progress
	Fast flashing 10s: Autosee failed
	Flashing in sync with Radio LED: Transmitter deletion in progress
	Lit 1s: Start/Stop after key S3 pressed
	Lit 10s: Autosee completed correctly

9) ADJUSTMENT PROCEDURE

- Before turning the unit on, check electrical connections.
- Set the following parameters: Automatic Closing Time, motor force, slow-down distance.
- Set the logics.
- Run the autosee function.

WARNING! Incorrect settings can result in damage to property and injury to people and animals.

WARNING: Check that the force of impact measured at the points provided for by standard EN 12445 is lower than the value laid down by standard EN 12453.

For best results, it is advisable to run the autosee function with the motors idle (i.e. not overheated by a considerable number of consecutive operations)

10) INSTALLATION TEST PROCEDURE

1. Run the AUTOSET cycle (*)
2. Check the impact forces: if they fall within the limits (**) skip to point 9 of the procedure, otherwise
3. Where necessary, adjust the sensitivity (force) parameter: see parameters table.
4. Check the impact forces again: if they fall within the limits (**) skip to point 9 of the procedure, otherwise
5. Apply a shock absorber profile
6. Check the impact forces again: if they fall within the limits (**) skip to point 9 of the procedure, otherwise
7. Apply pressure-sensitive or electro-sensitive protective devices (such as a safety edge) (**)
8. Check the impact forces again: if they fall within the limits (**) skip to point 9 of the procedure, otherwise
9. Make sure all devices designed to detect obstacles within the system's operating range are working properly

(*) Before running the autosee function, make sure you have performed all the assembly and make-safe operations correctly, as set out in the installation warnings in the drive's manual.

(**) Based on the risk analysis, you may find it necessary to apply sensitive protective devices anyway

WARNING! Incorrect settings can result in damage to property and injury to people and animals.



LED ERR:

Led SET	Led ERR		
	Lit	slow flashing	fast flashing
Unlit:	<u>Reverse due to obstacle - Amperostop</u> - Check for obstacles in path	<u>Photocell test, Costa o Costa 8k2 failed</u> - Check photocell connection and/or logic settings	Thermal cutout - Allow automated device to cool
Lit	<u>Internal system supervision control error.</u> - Try switching the board off and back on again. If the problem persists, contact the technical assistance department.		Limit switch error - Check limit switch connections
slow flashing		<u>Photocell test failed</u> - Check photocell connection and/or logic settings	<u>Parameters and/or Operating Logic edited</u> - If the "Slow-down distance" is edited, run a new Autosee cycle to confirm the new setting. - If other parameters and/or operating logic are edited, hold down S2 for 5s to confirm. NOTE: In any case, the Autosee function confirms all changes made to the board.

INSTALLATION MANUAL

D812059 00100_02

TABLE "A" - PARAMETERS

TRIMMER	Parameter	 min.	 max.	Description
T1	Automatic closing time [s]	0	120	Waiting time before automatic closing. NOTE: Set to 0 if not used.
T2	Leaf force [%]	10	100	Force exerted by leaf/leaves. This is the percentage of force delivered, beyond the force stored during the autosect cycle (and subsequently updated), before an obstacle alarm is generated. ⚠ WARNING: It affects impact force directly: make sure that current safety requirements are met with the set value (*). Install anti-crush safety devices where necessary.
T3	Slow-down distance [%]	5	50	Set slow-down speed as a percentage of total travel. This distance is travelled at low speed. NOTE: When this parameter is edited, a new Autosect cycle must be run to confirm it.
T4	Motor 1 closing delay time [s]	0	25	Motor 1 closing delay time with respect to motor 2. NOTE: set 0 for single motor operations (leaf 1).

(*) In the European Union, apply standard EN 12453 for force limitations, and standard EN 12445 for measuring method.

TABLE "B" - LOGICS

DIP	Logic	Default	Cross out setting used	Description																	
1	Transmitter programming	ON	ON	Enables wireless memorizing of transmitters: 1- Press in sequence the hidden key and normal key (T1-T2-T3-T4) of a transmitter that has already been memorized in standard mode via the radio menu. 2- Press within 10 sec. the hidden key and normal key (T1-T2-T3-T4) of a transmitter to be memorized. The receiver exits programming mode after 10 sec.: you can use this time to enter other new transmitters. This mode does not require access to the control panel. IMPORTANT: Enables the automatic addition of new transmitters, clones and replays.																	
			OFF	Disables wireless memorizing of transmitters and automatic addition of clones. Transmitters are memorized only using the relevant Radio menu or automatically with replays. IMPORTANT: Disables the automatic addition of new transmitters and clones																	
2	BAR / 8K2	OFF	ON	Input configured as Bar 8k2 (Fig.H, ref.5). Input for resistive edge 8K2. The command reverses movement for 2 sec.																	
			OFF	Input configured as Bar, safety edge (Fig.H, ref.3-4). The command reverses movement for 2 sec..																	
3	Photocell input check	OFF	ON	Enable safety check on the PHOT input																	
			OFF	Safety check on PHOT input not enabled																	
4	Edge input check	OFF	ON	Enable safety check on the BAR input																	
			OFF	Safety check on BAR input not enabled																	
5	Photocells during closing	OFF	ON	In the event beam is broken, photocell operation is disabled during opening. During closing, movement is reversed immediately.																	
			OFF	When beam is broken, photocells are active during both opening and closing. When beam is broken during closing, movement is reversed only once the photocell is cleared.																	
6	Fast closing	OFF	ON	Closes 3 seconds after the photocells are cleared before waiting for the set TCA to elapse.																	
			OFF	Logic not enabled																	
7	Block pulses during opening	OFF	ON	The start pulse has no effect during opening.																	
			OFF	The start pulse has effect during opening.																	
8	3-step logic	OFF	ON	Switches to 3-step logic; during closing, start reverses movement.																	
			OFF	Switches to 4-step logic.																	
<table border="1" style="width: 100%; border-collapse: collapse;"> <thead> <tr> <th></th> <th>3 step</th> <th>4 step</th> </tr> </thead> <tbody> <tr> <td>CLOSED</td> <td rowspan="2">opens</td> <td>opens</td> </tr> <tr> <td>DURING CLOSING</td> <td>stop</td> </tr> <tr> <td>OPEN</td> <td>closes</td> <td>closes</td> </tr> <tr> <td>DURING OPENING</td> <td>stop + TCA</td> <td>stop + TCA</td> </tr> <tr> <td>AFTER STOP</td> <td>opens</td> <td>opens</td> </tr> </tbody> </table>						3 step	4 step	CLOSED	opens	opens	DURING CLOSING	stop	OPEN	closes	closes	DURING OPENING	stop + TCA	stop + TCA	AFTER STOP	opens	opens
	3 step	4 step																			
CLOSED	opens	opens																			
DURING CLOSING		stop																			
OPEN	closes	closes																			
DURING OPENING	stop + TCA	stop + TCA																			
AFTER STOP	opens	opens																			
9	Hammer during opening	OFF	OFF	Logic not enabled																	
			ON	Before opening completely, the gate pushes for approx. 2 seconds as it closes. This allows the solenoid lock to be released more easily. IMPORTANT - Do not use this function if suitable mechanical stops are not in place.																	
10	Closing limit switch pressure	OFF	OFF	Movement is stopped only when the closing limit switch trips: in this case, the tripping of the closing limit switch must be adjusted accurately (Fig.G Ref.B).																	
			ON	Use when there is a mechanical stop in closed position. This function allows leaves to press against the mechanical stop without the Amperestop sensor interpreting this as an obstacle. Thus the rod continues its stroke for a few seconds after meeting the closing limit switch or as far as the mechanical stop. In this way, the leaves come to rest perfectly against the stop by allowing the closing limit switches to trip slightly earlier (Fig.G Ref.A).																	