

SL1000AC/SL1500AC Sliding Gate Opener User Manual

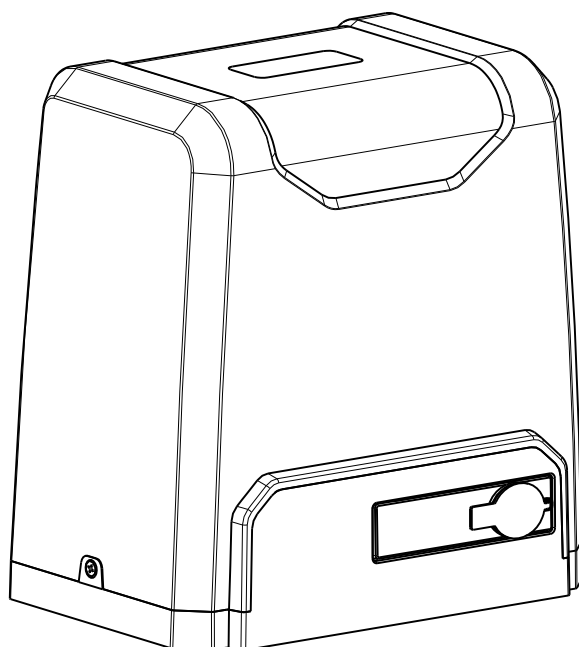

Dear users,

Thank you for choosing this product. Please read the manual carefully before assembling and using it. Please do not leave out the manual if you send this product to a third party.

1. Safety Instruction



Please ensure that the using power voltage matches with the supply voltage of gate opener (AC110V or AC220V); kids are forbidden to touch the control devices or the remote-control unit.

The remote-control unit is controlled by a single button mode or three button mode (please refer to the instructions of the remote control in accordance with the actual gate opener type). The indicator light on the remote-control unit will flicker when the button on it is pressed. Main engine and gate can be unlocked by disengagement wrench and the gate can move with manual operation after disengagement.

Please ensure that no one is around the main engine or gate when the switch is operated and it is usually demanded to examine the stability of installation. Please temporarily stop using if the main engine needs repairing or regulation.

The installation and maintenance of the products must be carried out by professionals.

2. Packing List (standard)

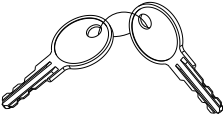
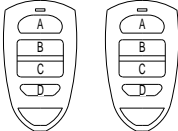
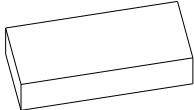
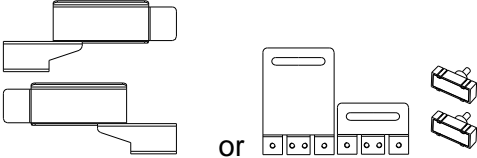
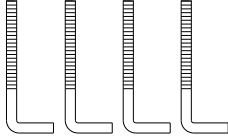
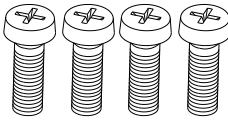
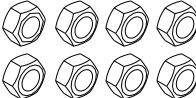
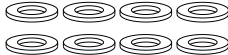
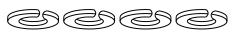
No.	Picture	Name	Quantity
1		Main engine	1
2		Manual release key	2
3		Remote control	2
4		Spring limit switch accessories box / Magnetic limit switch accessories box	1
4-1		Spring limit switch block / Magnetic limit switch block	1
4-2		Foundation bolt M10	4
4-3		Spring limit switch block mounting screw M6X10 / Magnetic limit switch block mounting screw M6X18	4
4-4		Nut M10	8
4-5		Flat washer Ø10	8
4-6		Spring washer Ø10	4

2. Packing List (optional)

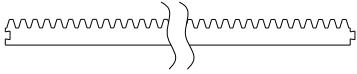
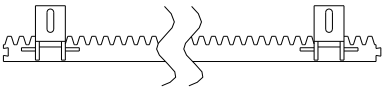
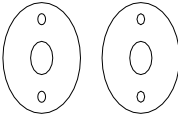
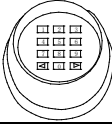
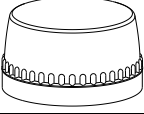
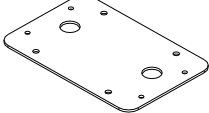
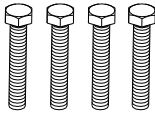
No.	Picture	Name	Quantity
1		Steel gear rack	1m/pc
2		Nylon gear rack	1m/pc
3		Infrared sensor	1
4		Wireless keypad	1
5		Alarm lamp	1
6		Mounting plate	1
7		Hexagon head bolt M10x60	4

3. Technical parameters

Model	SL1000AC	SL1500AC
Power supply	220V/50Hz;110V/60Hz	220V/50Hz;110V/60Hz
Motor power	400W	550W
Gate moving speed	11-13m/min	11-13m/min
Maximum weight of gate	1000Kg	1500Kg
Remote control distance	≥30m	≥30m
Remote control mode	Single button mode / Three button mode	Single button mode / Three button mode
Limit switch	Spring limit switch Magnetic limit switch	Spring limit switch / Magnetic limit switch
Noise	≤60dB	≤60dB
Working duty	S2, 20min	S2, 20min
Recording of up remote controls	25	25

Frequency	433.92 MHz	433.92 MHz
Working temperature	-20°C ~ +70°C	-20°C ~ +70°C
Package weight	15Kg	16Kg

4. Installation

SL1000AC/SL1500AC sliding gate opener is applicable to gate weight less than 1000kg/1500kg, and length of the sliding gate should be less than 12m. The drive mode adopts the gear and rack transmission. This gate opener must be installed inside the enclosure or yard for protection.

4.1 Installation drawing

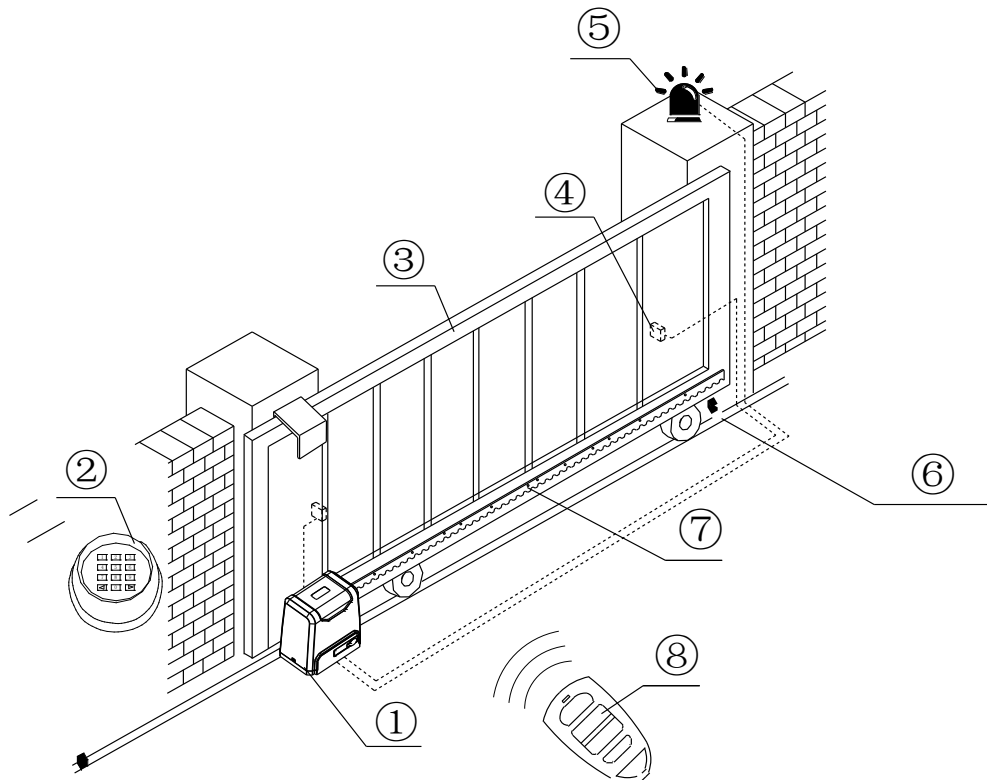

Figure 1

- ① Gate opener; ② Wireless keypad (optional); ③ Gate; ④ Infrared sensor (optional);
 ⑤ Alarm lamp (optional); ⑥ Safety stop block; ⑦ Gear rack; ⑧ Remote control;

4.2 Size of main engine and accessories

4.2.1 Size of main engine

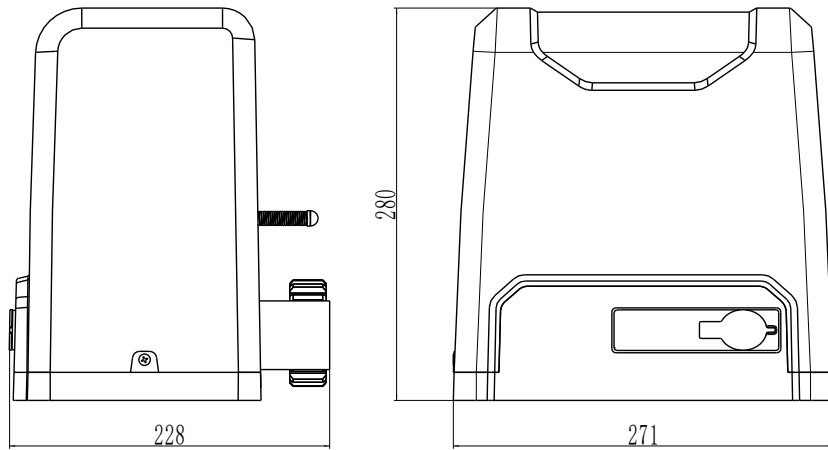

Figure 2

4.2.2 Size of mounting plate

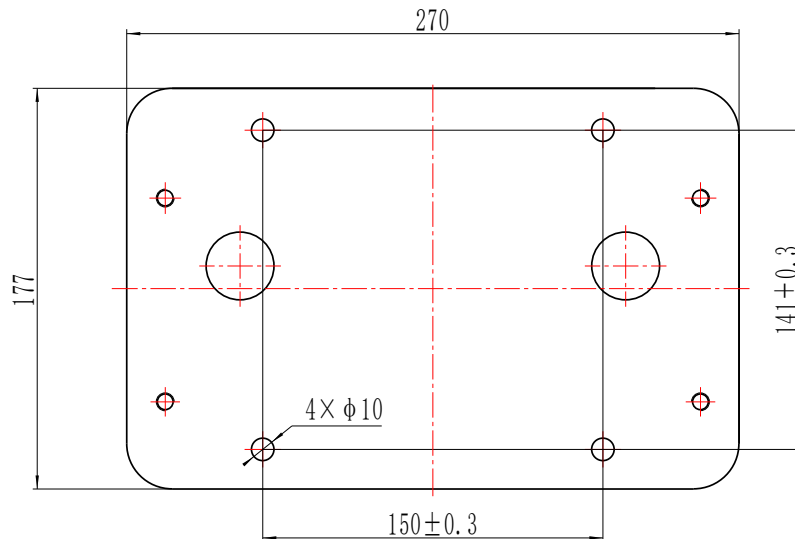

Figure 3

4.3 Installation procedures

4.3.1 Preparation work before installation

Please ensure that the sliding gate is correctly installed, the gate rail is horizontal, and the gate can glide back and forth smoothly when moved by hands before installing the gate opener.

Cable installation

Please bury the motor & power cable and controlling cable with PVC tube, and use two PVC tubes to bury (motor & power cable) and (controlling cable) separately, so as to guarantee normal operation of the gate opener and protect the cables from damages.

Concrete pedestal

Please cast a concrete pedestal with the size of 500mm x 300mm and depth of 250mm in advance, so as to firmly install SL1000AC/SL1500AC gate opener. **Please verify whether the distance between the gate and gate opener is suitable before casting the pedestal.**

Embedded screws

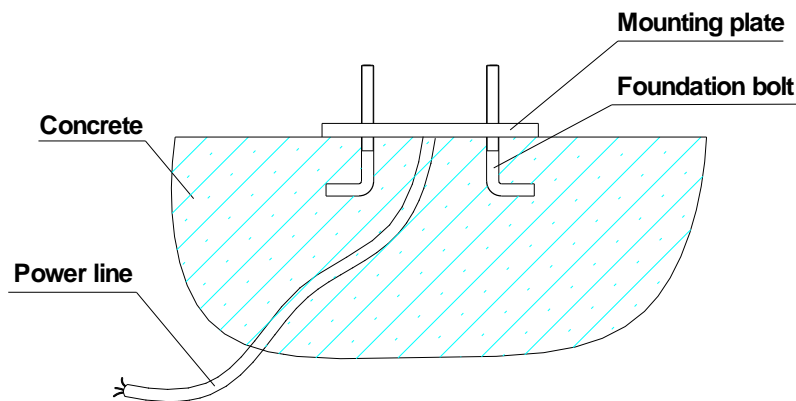

Figure 4

4.3.2 Main engine installation

- Dismantle the plastic housing on the main engine before installation and keep relevant fasteners properly;
- Please prepare the power line for connecting mounting plate and main engine (the number of power supply cable core shall not be less than 3 PCS, the sectional area of cable core shall not be lower than 1.5mm^2 and the length shall be determined by users according to the field situation) due to different installation environments;
- Please unlock the main engine before installation, the unlock method is: take out the key cover, insert the key, and open the manual release bar till it rotates by 90° as shown in Figure 5. Then turn the output gear and the gear can be rotated easily;

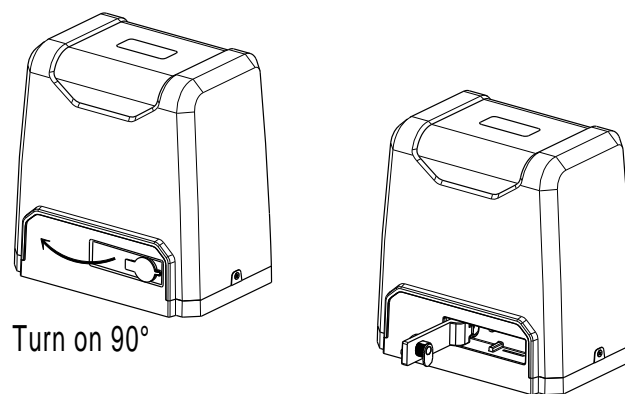

Figure 5

4.3.3 Gear rack installation

- Fix the mounting screws to the rack.
- Put the rack on the output gear, and weld the mounting screw to the gate (each screw with one solder joints firstly).
- Unlock the motor and can pull the gate smoothly.
- Please check whether there is a fit clearance between rack and output gear, as shown in Figure 7.

- Weld all the mounting screws to the gate firmly.
- Make sure that all racks on the same straight line.
- Pull the gate after installed, make sure the entire trip is flexible no stuck.

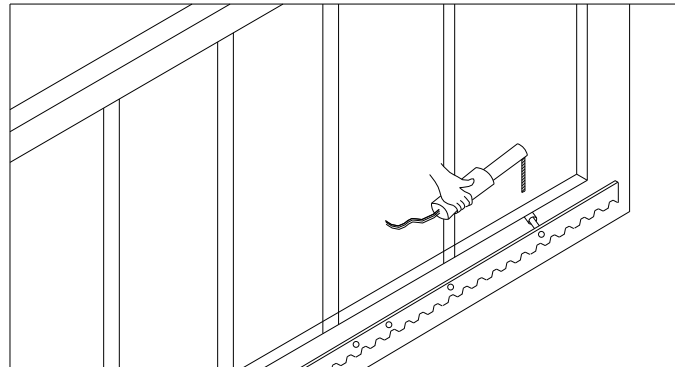

Figure 6

The fit clearance of output gear and rack is shown in Figure 7 below:

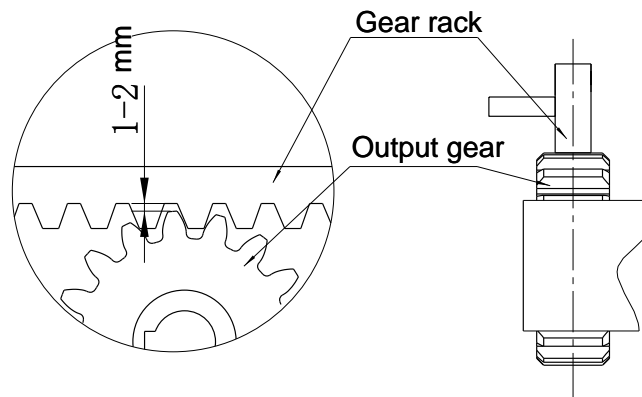

Figure 7



Warnings

- To ensure safety, install safety stop blocks on both ends of the rails to prevent the gate out of the rail. Before installing the main engine, make sure that the safety stop blocks are in place and whether it has the function of preventing the gate from moving out of the rail and out of the safety range.
- Please ensure that the main engine and its components have good mechanical properties, and the gate can operate flexibly when moved by hands before installing the main engine.
- In this product, one control can drive one main engine only, otherwise, the control system will be damaged.
- Earth leakage circuit breaker must be installed where the gate movement can be seen, and the minimum mounting height is 1.5m to protect it from being touched.
- After installation, please check whether the mechanical property is good or not, whether gate movement after manual unlocking is flexible or not, and whether the infrared sensor (optional) is installed correctly and effectively.

4.3.4 Limit switch adjustment

Spring limit switch - The installation site of spring limit switch is shown in Figure 8:

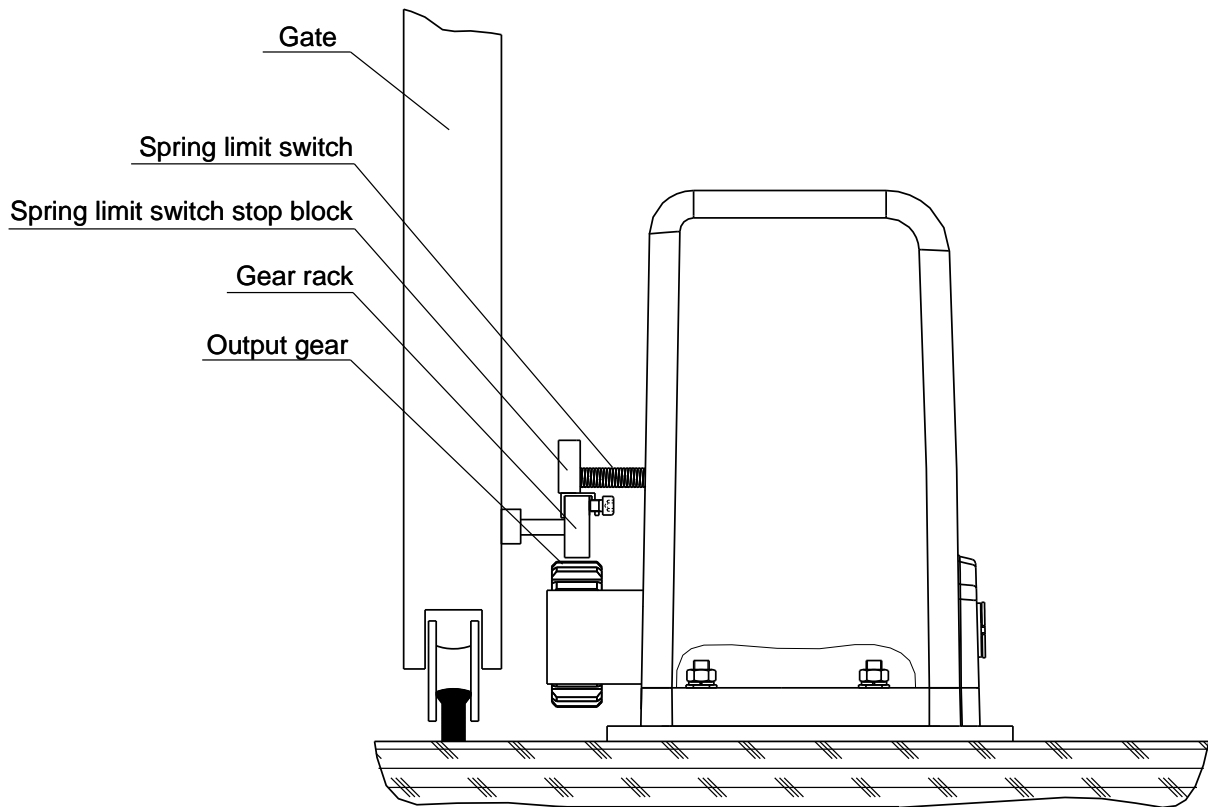

Figure 8

The installation of spring limit switch stop block is shown in Figure 9:

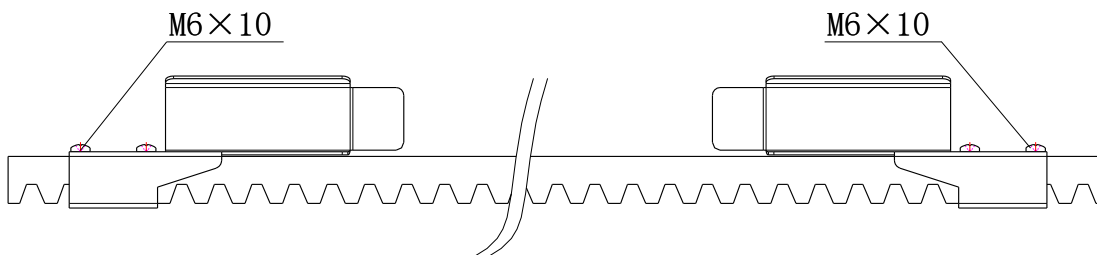

Figure 9

Magnetic limit switch - The installation site of magnetic limit switch is shown in Figure 10:

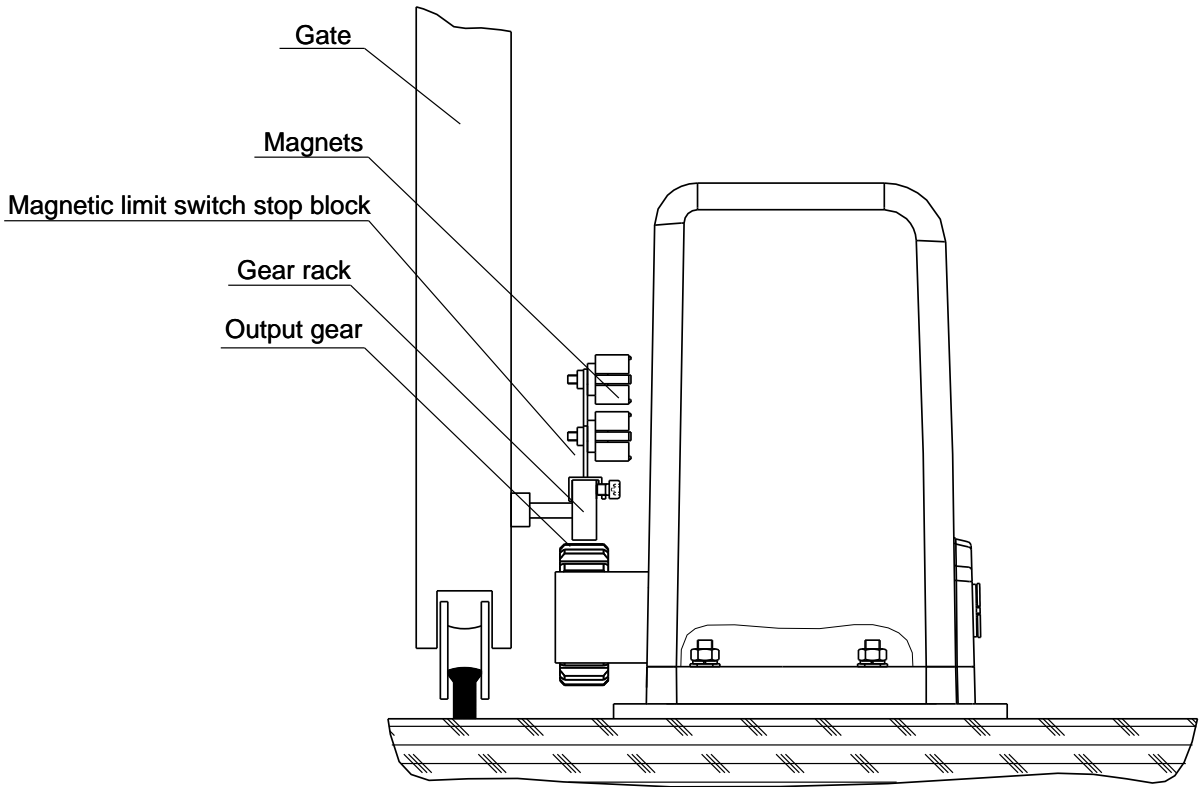

Figure 10

The installation of magnetic limit switch block is shown in Figure 11:

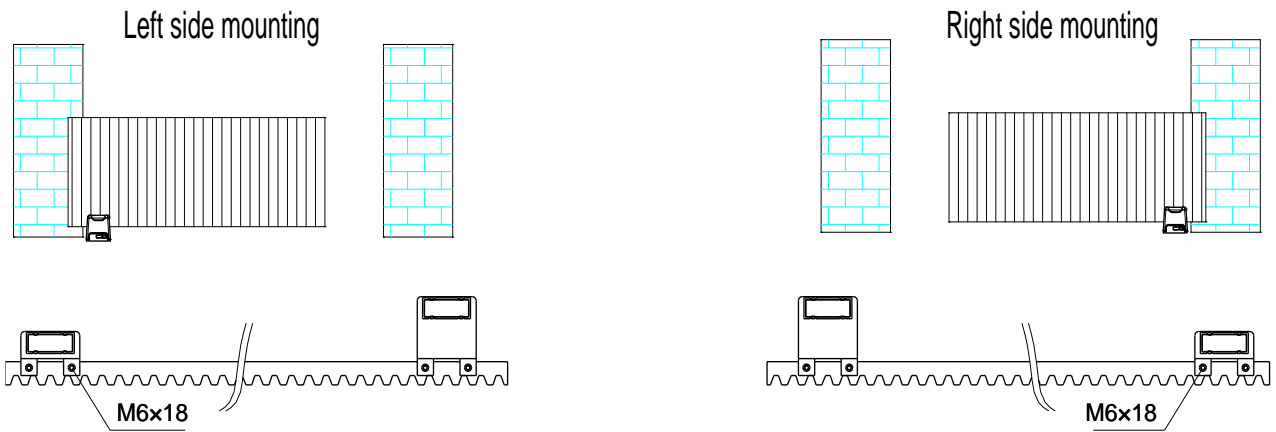

Figure 11

Note: The default setting is right side mounting. (According to actual situation, please refer to the “Note” of section 4.3.5.1 and 4.3.5.2 “Adjustment and operation” to adjust.)

4.3.5 Control board wiring

4.3.5.1 Standard control board

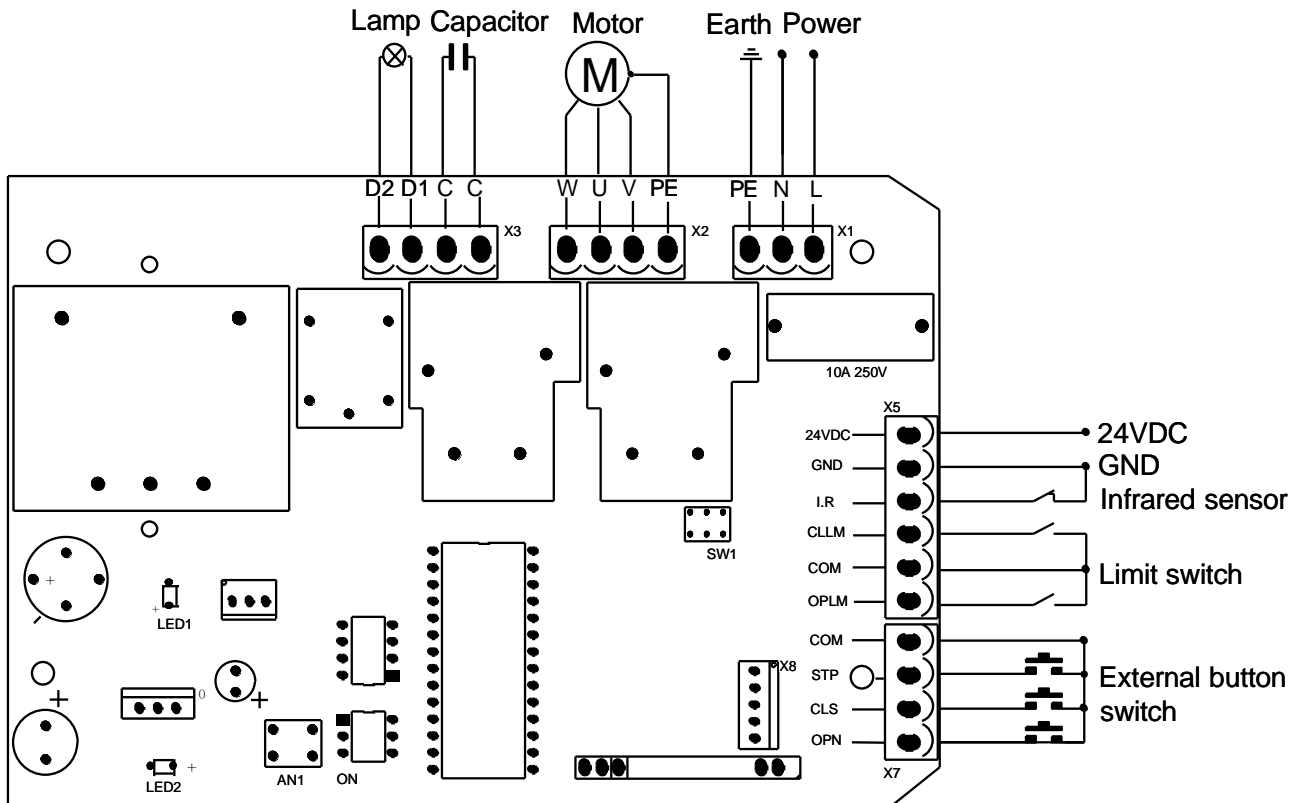

Figure 12

Wiring instruction:

1. Connect L and N to the power supply of AC220V/50HZ; AC110V/60HZ; L is live wire, N is Neutral wire, and PE is grounding wire.
2. Connect LAMP to D1, D2; voltage: AC220V/50HZ; AC110V/60HZ.
3. Connect the motor wire U to the REV motor wire, connect W to the FWD motor wire, and connect V to the motor common wire.
4. Connect C, C to the capacitor wire.

X5 Terminal

24VDC	Power supply for fittings +24VDC (Electric current $\leq 50\text{mA}$);
GND	Power ground;
I.R	Photocell input (N.C.);
CLLM	Close limit switch;
COM	Limit switch common terminal;
OPLM	Open limit switch.

X7 Terminal

COM	Control button common terminal;
STP	Stop control button (N.O.);
CLS	Gate close control button (N.O.);
OPN	Gate open control button (N.O.).

DIP Switch

1. External button switch. ON - Three button switch; OFF - One button switch (X7 terminal CLS button can be used to circularly control the main engine OPEN/STOP/CLOSE/STOP).

2. Automatic close time.

3. Automatic close time.

2 ON 3 OFF: automatic close time is 15s,

2 OFF 3 ON: automatic close time is 30s,

2 OFF 3 OFF: automatic close time is 45s,

2 ON 3 ON: no automatic close function.

Infrared connection

Infrared photocell function: In the closing process, when infrared ray of the infrared sensor is covered, the gate will open immediately, to protect user and property security.

The distance between photocell receiver and photocell emitter should be not less than 2 meters, otherwise will affect the induction of the photocell.

If connect the infrared photocell, please remove the short connection between I.R and GND on the X5 terminal.

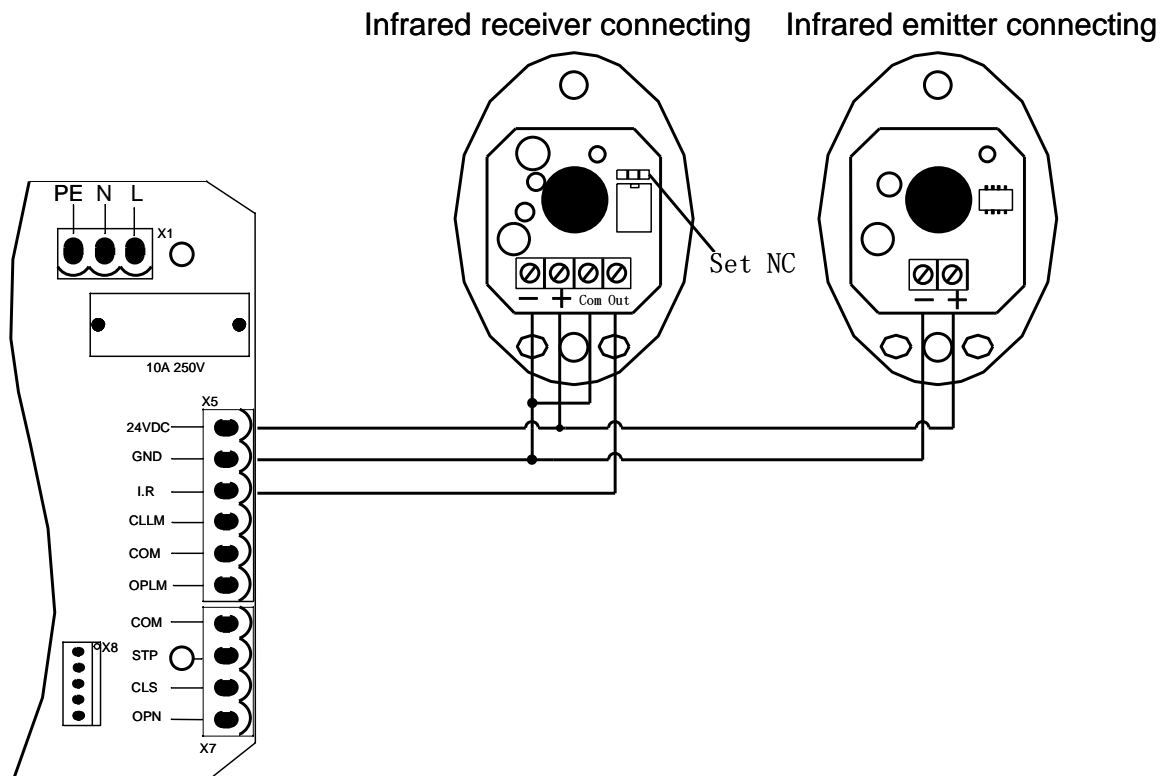

Figure 13

Adjustment and operation

Remote control operation

When remote control is three button mode, three buttons on the remote control to control the main engine OPEN/CLOSE/STOP separately.

When remote control is single button mode, one same button on the remote control to circularly control the main engine OPEN/STOP/CLOSE/STOP.

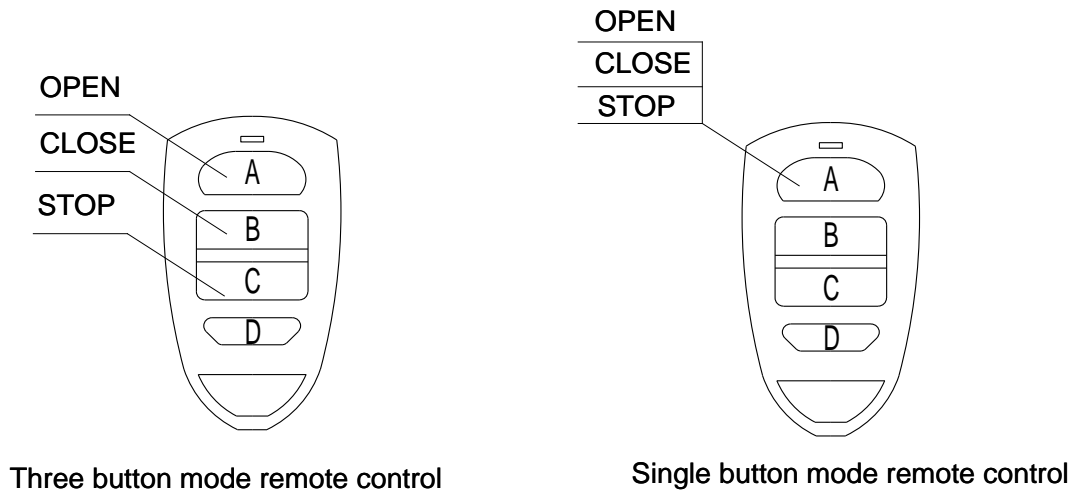

Figure 14

Add extra remote control (remote control learning): Remove the upper cover of main engine, remove the upper cover of the control box, press the learning button AN1 on the control board, and indicator light LED2 will flash once and then go out; press the same button on the remote control twice, the LED2 flashes repeatedly and then goes out; remote control learning is succeed. At most 25 remote controls can be learned.

Delete remote control: Delete remote control that have been learned; press the learning button AN1 and LED2 will be on; loosen the button until LED2 is off. This indicates that all remote controls that learned previously have been deleted.

Note: To disengage gate opener, move the gate to the middle position, then close the clutch and press the open button of external button switch to open the gate. **If the gate opening direction is wrong, can through the toggle switch SW1 on the control board or exchange the two motor lines U and W. Please seriously observe whether the motor can stop automatically when the gate fully opened. If the position cannot be limited correctly, please exchange limit switch lines CLLM and OPLM.**

4.3.5.1 Intelligent control board

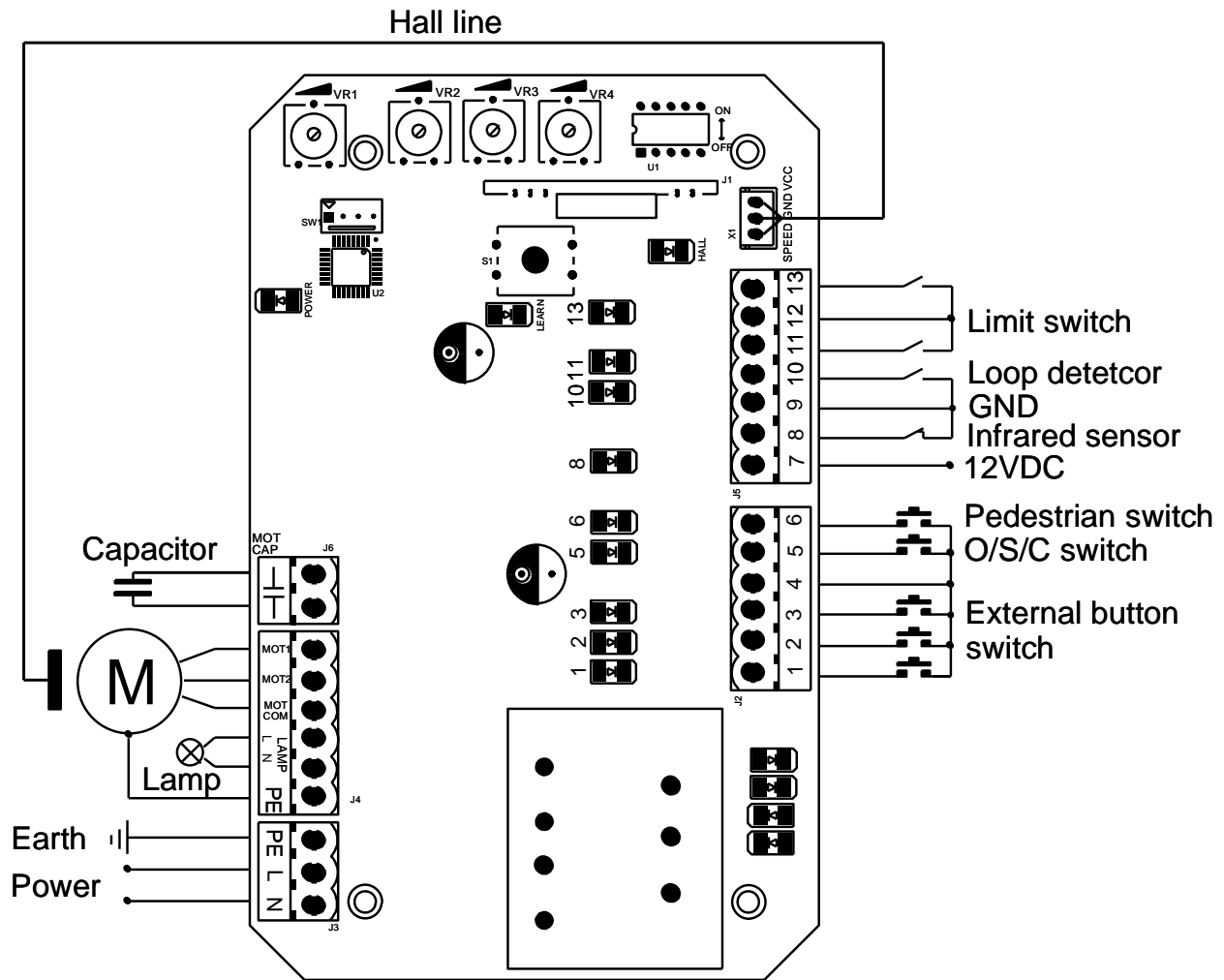

Figure 15

Wiring instruction:

1. Connect L and N to the power supply of AC220V/50HZ; AC110V/60HZ; L is live wire, N is Neutral wire, and PE is grounding wire.
2. Connect LAMP to caution light; voltage: AC220V/50HZ; AC110V/60HZ.
3. Connect the motor wire MOT2 to the REV motor wire, connect MOT1 to the FWD motor wire, and connect MOTCOM to the motor common wire.
4. Connect MOTCAP to the capacitor wire.

J2 (For the convenience of wiring, this terminal is accompanied with failure diagnosis light)

1. Gate close control button (N.O.)
2. Gate open control button (N.O.)
3. Stop control button (N.O.)
4. Control button common terminal
5. Open/Stop/Close/Stop loop control button (N.O.)
6. Pedestrian mode control button (N.O.)

J5 (For the convenience of wiring, this terminal is accompanied with failure diagnosis light)

7. Power supply for fittings: +12V (Electric current $\leq 100\text{mA}$)

8. Photocell input (N.C.); short out the device if not used.

9. GND

10. Loop detector (sensor coil) connector (N.O.)

In the closing process, once vehicles are detected by the loop detector, the gate will open soon; when the vehicle passes, the gate will close automatically. When the gate is in a halted state, it will keep this state when vehicles are detected; after the vehicle passes, the gate will close automatically.

In the above loop detector function, users can make the gate close automatically 12 seconds later after the vehicle passes. Change the No.4 key of the dip switch on circuit board, and the gate will close automatically 12 seconds later after the vehicle passes.

11. Close limit switch

12. Limit switch and other input signal common terminal

13. Open limit switch

Function adjustment

Functional parameters of the control board equipped with microprocessor can be adjusted through potentiometer and dip switch, so as to meet different installation requirements.

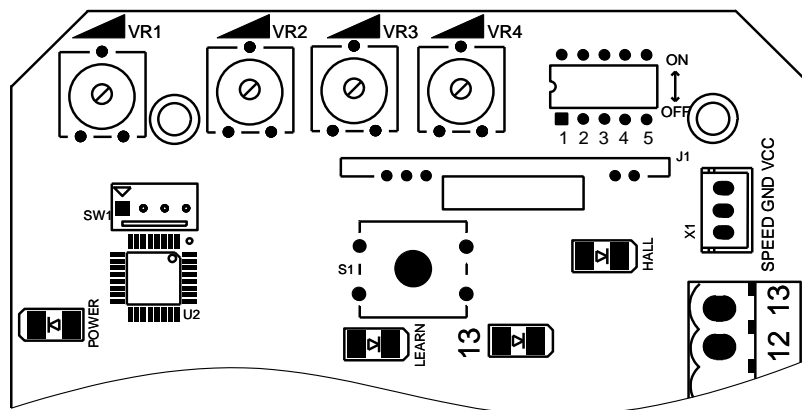

Figure 16

Adjusting knob

VR1: When meet obstacle reverse function is enabled (DIP switch 5 at OFF position and the motor assembled the hall line). This knob is used for sensitivity adjustment of meet obstacle.

Clockwise rotation to reduce sensitivity of obstacle, counter-clockwise rotation to increase sensitivity of obstacle.

When meet obstacle reverse function is disabled (DIP switch 5 at ON position). This knob is used for motor working total time adjustment. Clockwise rotation to increase, counter-clockwise rotation to reduce. The total time can be set to 10 seconds as minimum and 90 seconds as maximum.

VR2: For brake force adjustment in limit position.

Clockwise rotation to increase, counter-clockwise rotation to reduce.

Rotate to minimum to cancel brake function in place.

VR3: For slow stop width adjustment.

Clockwise rotation to increase, counter-clockwise rotation to reduce.

VR4: For motor output force adjustment to keep safe usage.

Clockwise rotation to increase, counter-clockwise rotation to reduce.

Note: the default setting is VR1, VR2, VR3, VR4 are the maximum value, and the user can adjust according to the actual requirement.

Warning: the motor output force cannot set too large, just to be able to drive the gate.

Dip switch

1. Soft start function. OFF - enabled; ON - disabled.
2. Limit switch setting. OFF- normal open (N.O.); ON - normal close (N.C.).
3. Automatic close time.
4. Automatic close time.

Setting for automatic close time:

3 OFF 4 ON: automatic close time is 12s,

3 ON 4 OFF: automatic close time is 24s,

3 ON 4 ON: automatic close time is 36s,

3 OFF 4 OFF: no automatic close function.

5. Meet obstacle reversal function. OFF - enabled; ON - disabled.

Infrared connection

Infrared photocell function: In the closing process, when infrared ray of the infrared sensor is covered, the gate will open immediately, to protect user and property security.

The distance between photocell receiver and photocell emitter should be not less than 2 meters, otherwise will affect the induction of the photocell.

If connect the infrared photocell, please remove the short connection between 8 and 9 on the J5 terminal.

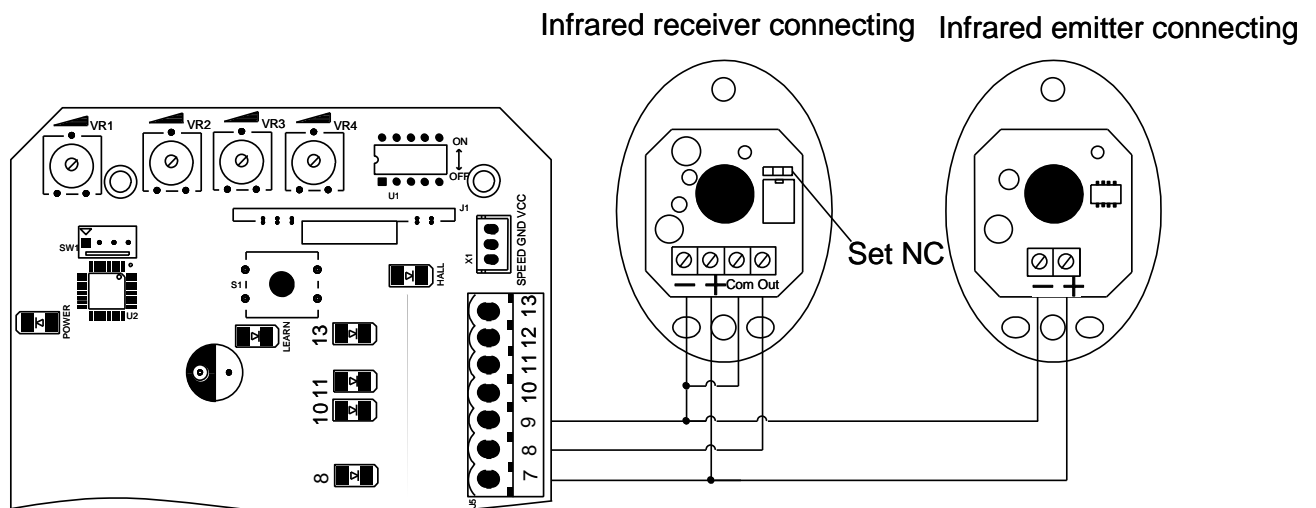

Figure 17

Adjustment and operation

Remote control operation

When remote control is three button mode, three buttons on the remote control to control the main engine OPEN/CLOSE/STOP separately.

When remote control is single button mode, one same button on the remote control to circularly control the main engine OPEN/STOP/CLOSE/STOP.

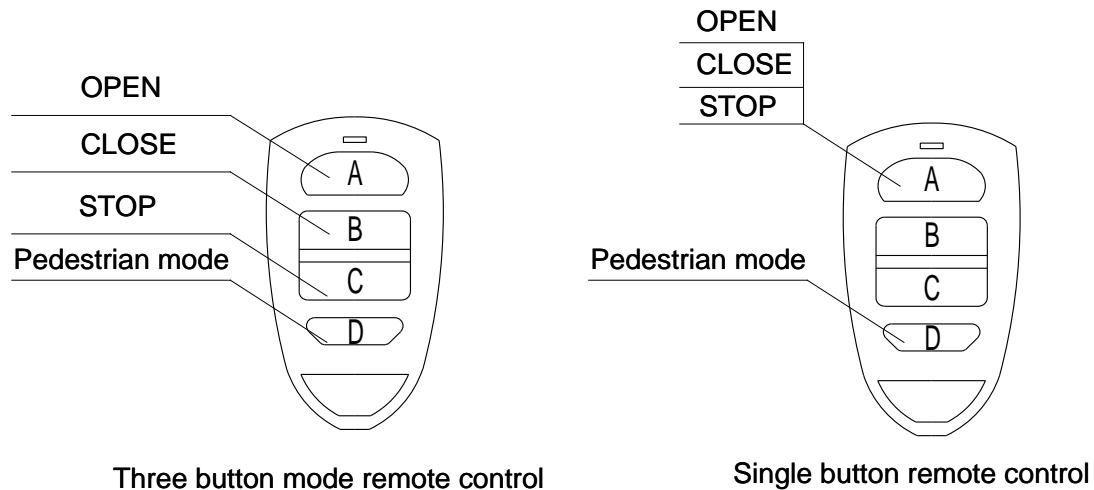

Figure 18

Add extra remote control (remote control learning): Remove the upper cover of main engine; press the learning button S1 on the control board, and indicator light LEARN will flash once and then go out; press the same button on the remote control twice, the LEARN flashes repeatedly and then goes out; remote control learning is succeed. At most 25 remote controls can be learned.

Delete remote control: Delete remote control that have been learned; press the learning button S1 and LEARN will be on; loosen the button until LEARN is off. This indicates that all remote controls that learned previously have been deleted.

The fourth button on the remote control is for pedestrian mode, press the button the door will open about 1 meter when the door is closed, for pedestrian only.

Note: To disengage gate opener, move the gate to the middle position, then close the clutch and press the open button of external button switch to open the gate. **If the gate opening direction is wrong, exchange the two motor lines MOT2 and MOT1. Please seriously observe whether the motor can stop automatically when the gate fully opened. If the position cannot be limited correctly, please exchange limit switch lines 11 and 13.**

5. Others

5.1 Maintenance

Check whether the gate operates normally every month.

For the sake of safety, each gate is suggested to be equipped with infrared protector, and regular inspection is required.

Before installation and operation of the gate opener, please read all instructions carefully.

Our company has the right to change the instruction without prior notice.

5.2 Troubleshooting

Problems	Possible Reasons	Solutions
The gate cannot open or close normally, and LED does not light.	<ol style="list-style-type: none"> 1.The power is off. 2.Fuse is burned. 3.Control board power wiring with problem. 	<ol style="list-style-type: none"> 1.Switch on the power supply. 2.Check the fuse (code FU), change the fuse if burnt. 3.Re wiring according to instructions.
The gate can open but cannot close.	<ol style="list-style-type: none"> 1.Photocell wiring with problem. 2.Photocell mounting with problem. 3.Photocell is blocked by objects. 4.Sensitivity of obstacle is too high (Intelligent type). 5.Hall switch parts is damaged (Intelligent type). 	<ol style="list-style-type: none"> 1.If not connect photocell, please make sure that the infrared port and GND short circuit; if connect infrared sensor, please make sure the wiring is correct and the photocell is N.C. 2.Make sure that the photocell mounting position can be mutually aligned. 3.Remove the obstacle. 4.Reduce the sensitivity of obstacle. 5.Change hall switch parts.
Remote control doesn't work.	<ol style="list-style-type: none"> 1.Battery level of the remote control is low. 2.Remote control learning is not completed. 	<ol style="list-style-type: none"> 1.Change the remote control battery. 2.Re-conduct remote control learning.
Press OPEN, CLOSE button, the gate is not moving, motor has noise.	<ol style="list-style-type: none"> 1.Capacitor is broken. 2.Capacitor is poor connected. 3.Gate moving is not smoothly. 	<ol style="list-style-type: none"> 1.Change capacitor. 2.Check the capacitor wiring. 3.According to the actual situation to adjust the motor or the gate.
Not stop at the limit position when opening / closing.	<ol style="list-style-type: none"> 1. The limit direction is wrong. 2. The mounting of magnetic limit switch with problem. 	<ol style="list-style-type: none"> 1.Check whether the limit switch wiring is consistent with the actual direction of operation. 2. Check whether the distance between magnetic limit switch and motor, and the height of the magnetic limit switch can reach up the mounting requirement.
Leakage switch tripped.	Power supply line short circuit or motor line short circuit.	Check wiring.

Remote control working distance is too short.	Signal is blocked.	Connect external receiver antenna, 1.5 meters above ground.
The gate moves to the middle position to stop or reverse.	<ol style="list-style-type: none"> 1.Motor output force is not enough (Intelligent type). 2.Sensitivity of obstacle is too big(Intelligent type). 3.Gate meets obstacle. 	<ol style="list-style-type: none"> 1.Adjust the VR4. 2.Adjust the VR1. 3.Remove the obstacle.